

# kPulley2 Manual



**EXXENTRIC**

---

Exxentric  
kPulley2 Manual  
Version 2.4.1 | 2021-12-23

---

Exxentric AB  
Karlsbodavägen 39  
168 67 Bromma  
Sweden

t: +46-733-55 90 49  
e: [info@exxentric.com](mailto:info@exxentric.com)



# WARNING

## For Your Safety

Please read and understand the user manual and warning labels prior to use.

- Inspect the machine including the drive belt before use. Damaged or worn parts and warning labels **must** be replaced. See user manual for how to change and cut the drive belt. Do not modify the machine or repair it with non OEM parts.
- Before you start training, make sure the pulley block snap shackle is properly closed and connected.
- Flywheels may get slippery when wet. When lifting flywheels, use a secure two-handed grip.
- The machine and accessories are intended for strength training only. Do not use them in any other way.
- The kPulley can deliver a supramaximal\* workload. Do not exercise at an intensity above your physical capacity.
- The device is not suitable for children or animals.

## During Use

Personal injuries may occur if the relevant precautions are not observed.

- Work out at a submaximal\*\* intensity until you are familiar with the equipment.
- Keep away from moving and/or rotating parts.
- Use shoes to avoid friction burns from the spinning flywheel or drive belt during use. Never stop a spinning flywheel with your bare hand as it may cause friction burns.
- Do not let the pulley block hit the kPulley height adjuster during use, absorb the eccentric load before it hits the device.
- If you feel dizzy or experience pain, stop exercising immediately.
- Exercising at maximum intensity may cause temporary staggering and uncontrolled body movements due to fatigue. Exercise caution to prevent falling.
- Exxentric takes no responsibility for any injuries that may occur while using this product.

\*) Supramaximal means higher than maximal. This means higher loads than your muscles can produce themselves in a shortening (concentric) action.

\*\*\*) Submaximal means below maximal. In this case, we would recommend below 75% of maximum intensity.

# CONTENTS

This Manual covers a description of the kPulley, a Multi-Exercise Flywheel Device, a guide to its use, and how to maintain it.

*Always check [exxentric.com/support](http://exxentric.com/support) for latest info and manuals.*



Specifications	6
kPulley2 Overview	7
Tool Kit Overview	8
Assembly and Mounting Instructions	9
Attaching the Drive Belt	12
Introduction	13
Features	14
Usage	15
kPulley Maintenance	17
Flywheel Workout Zones	19
kMeter	20
kPulley Accessories	21
Support	22
Apps	23
Warranty	24

---

## Caution!

Like any exercise program, it is important that users are capable of performing exercises on this exercise equipment and have verified this with their personal physician.

# SPECIFICATIONS

	<b>kPulley2</b>
<b>Minimum dimensions (bounding box)</b>	
Width (incl. foot protection)	36.5 cm (14.4 inches)
Width on wall	5 cm (2 inches)
Depth (incl. foot protection)	38.5 cm (15.2 inches)
Height	225 cm (88.6 inches)
Mounting holes size	7 mm (0.3 inches)
<b>Materials</b>	
Chassis	steel
Beam	steel
Foot protection	steel
Flywheel	steel
Color	Midnight Blue, Jet Black  
<b>Features</b>	
Working height	34 cm - 225 cm (13.4 - 88.6 inches)
Range of motion*	1.5 m (59 inches)
kMeter II	built-in
Inertia range kgm <sup>2</sup>	0.005-0.140
Inertia factor**	x28
<b>Flywheel options (kgm<sup>2</sup>)</b>	
XS - 0.005	yes
S - 0.010	yes
M - 0.025	yes
L - 0.050	yes
XL - 0.070	yes
<b>Weight of machine</b>	16 kg (35.3 lbs)

\*) This range of motion is when the height adjuster is in middle position on the beam. Depending on the position of the height adjuster this range will increase or decrease in value.

\*\*) Inertia factor means the highest possible inertia divided by the lowest possible inertia. With the advanced flywheel knob it is possible to reach an inertia factor of x56 and an inertia range of 0.005 to 0.280 kgm<sup>2</sup>.

# KPULLEY2 OVERVIEW

*Detailed overview in printed manual.*

# TOOL KIT OVERVIEW



**Tool bag**

Contains everything listed below



**Wrenches 13mm**

For mounting the beam to the base unit



**M8x65 bolts  
& M8 nuts**

For mounting the beam to the base unit



**M6x16 screws  
& T30 torx key**

For securing the foot protection. The T30 torx key is also used to remove the shaft cover



**3 mm hex key**

For tightening flange position screws/shaft position screws and to remove lock pin.



**Lock pin**

For locking the drive belt to the shaft (one spare if the other one is lost)



# ASSEMBLY AND MOUNTING INSTRUCTIONS

Screws for mounting are not included, use the appropriate screws for your wall specifications. Exxentric takes no responsibility for the mounting of this product and recommends **seeking assistance from a professional.**

Unpacking and assembly video can be found here:  
[www.exxentric.com/support/manuals](http://www.exxentric.com/support/manuals)

## Beam Overview

The kPulley2 comes with a beam option of your choice. The M Beam can be used as a more portable alternative to the full L and XL beams.

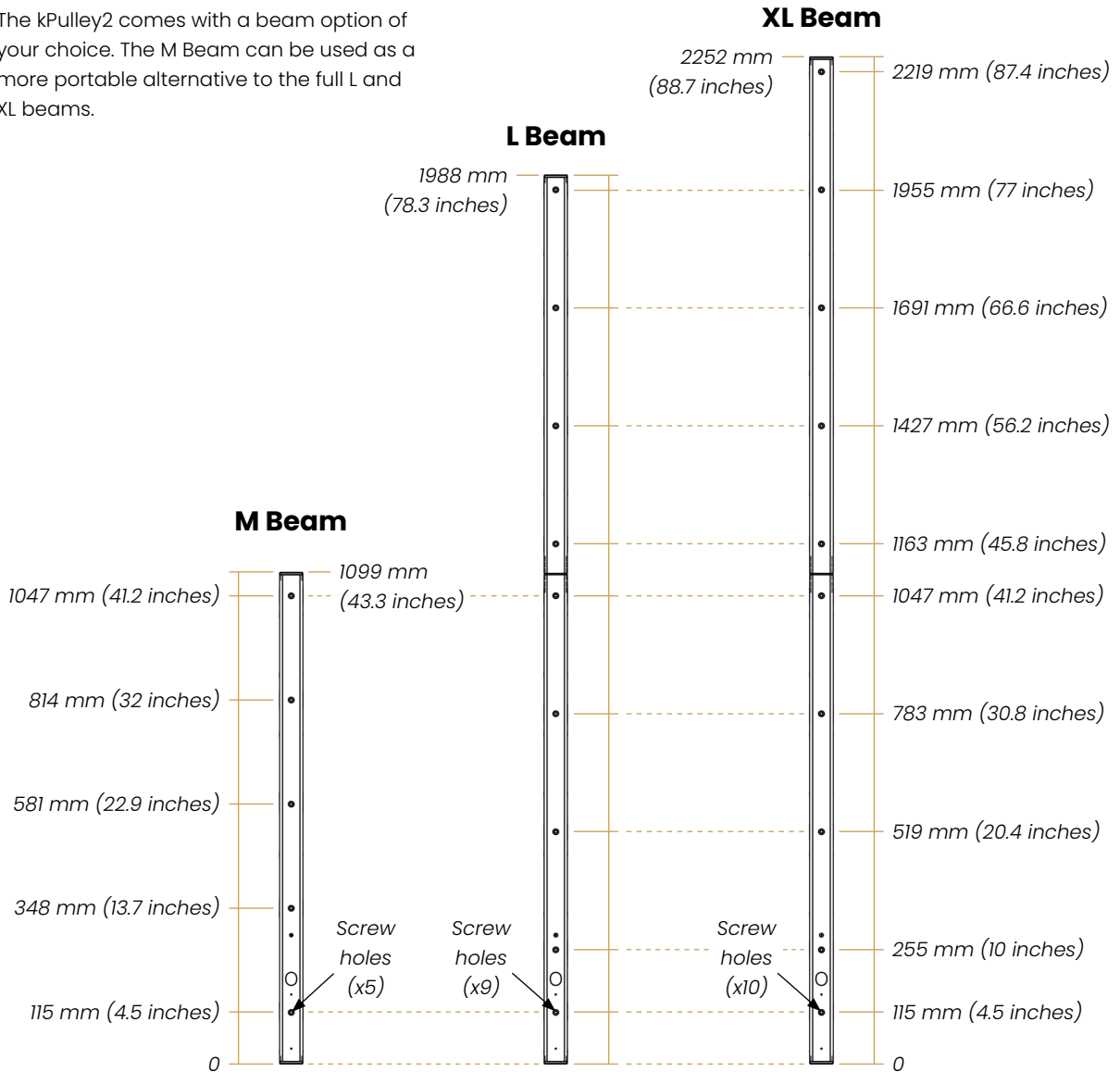

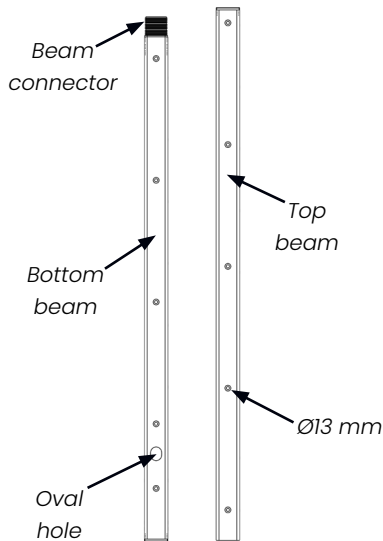

## Assembly

### Step 1

Insert the bottom beam into the top beam. Press the beams together firmly and ensure there are no gaps between the beams and the beam connector.

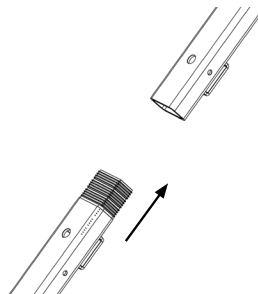

The holes for the screws on the back of the beam are 7 mm in diameter.

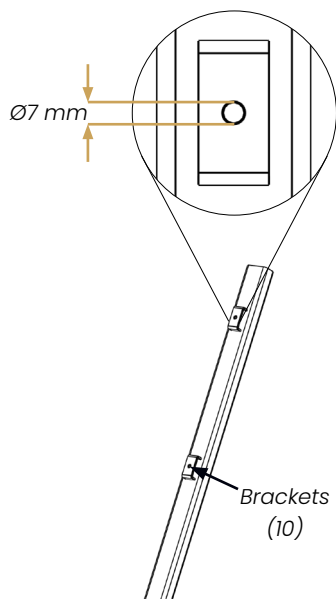

### Step 2

Screw the assembled kPulley beam onto the wall. **Make sure that the oval hole is at the bottom and is facing away from the wall.**

**Note:** To ensure the beam gets attached properly, screw it into the wall loosely and slide the height adjuster over the beam connector. If this runs smoothly, remove the height adjuster and tighten the screws closest to the split first then proceed to tighten the remaining screws.

**Tip 1:** When attaching the beams onto uneven surfaces, to get the split area straight, first attach a straight wooden beam to the surface. Then attach the kPulley to the wooden beam instead.

**Tip 2:** If you want the kPulley to stand on the floor, place the beam on the floor when attaching it to the wall.

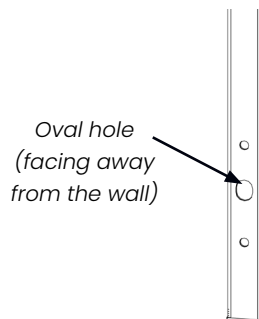

### Step 3

Attach the foot protection using the four M6x16 screws and the T30 torx key found in the tool bag.

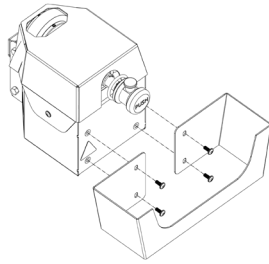

### Step 4

Attach the kPulley base unit & foot protection to the kPulley beam with the two M8x65 bolts and the two M8 lock nuts. Use the two 13mm wrenches.

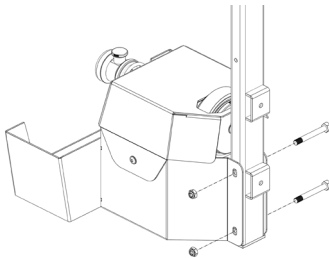

### Step 5

Slide on the height adjuster and then the belt stop.

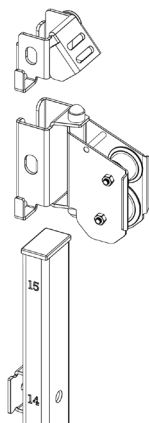

# ATTACHING THE DRIVE BELT

## Step 1

Pull out the drive belt, the Exxentric logo should face the beam as seen in the second image below.



Scan for a video tutorial on these steps!



## Step 2

Keep the logo of the drive belt facing the beam. Pull the drive belt behind the bottom wheel of the height adjustment pulley, over the bottom wheel and then horizontally outwards from the beam.

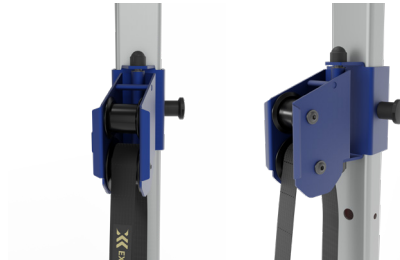

## Step 3

Take the small pulley block, pull the drive belt around the black wheel and then back towards the height adjustment pulley.



## Step 4

Pull the drive belt over the upper plastic wheel, under the metal rod and then up towards the belt stop.



## Step 5

Pull the drive belt in through the upper slot of the belt stop and then out through the lower slot.



## Step 6

Put the magnetic piece of the drive belt on the beam and start training!



# INTRODUCTION

## Setting up the kPulley

The kPulley must be firmly fixed to a wall or column. Use the designated (round) holes in the center of the beam or fix using a strong belt in the bent metal pieces on the back of the beam.

## Foot Protection

We recommend having the foot protection attached to the kPulley, in order to protect the user from injury.



## The Flywheel



We offer five differently sized flywheels with inertia: 0.005, 0.010, 0.025, 0.050 and 0.070 kgm<sup>2</sup>.

All flywheels from the kBox4 generation are compatible with the kPulley. The kPulley can hold a maximum of 2 flywheels at a time. This allows for a range of inertia between 0.005 and 0.140 kgm<sup>2</sup>\*.

**Do not try to mount more than the maximum capacity of flywheels.**

Experimentation will determine which configuration is required for your level of training. Mounting or changing flywheels is done by releasing the flywheel knob by pulling the pull pin knob on its side, removing the flywheel knob, changing flywheel(s) and securing them by pushing the flywheel knob back on until it makes a clicking noise.



**Tip:** If the black pull pin knob is hard to pull out, you can push the flywheel knob in whilst pulling the black pull pin knob out.

\*) With the advanced flywheel knob you can attach 4 flywheels to the kPulley, meaning you can achieve an inertia factor of x56 and an inertia range of 0.005 to 0.280 kgm<sup>2</sup>.

# FEATURES

## Principle of the kPulley

The kPulley is a 'multi-exercise flywheel device'. Which muscle is being exercised depends on which exercise is being performed.

The principle is that through muscular force you accelerate and decelerate a flywheel (or flywheels). Exercises with high intensity and high forces stimulate the muscles to increase in size and the nervous system to increase activation of the muscles. These effects together increase strength over time if the exercise is repeated regularly.

## Resistance

**The resistance is variable and unlimited.**

The flywheel has a specified inertia and there is no upper limit to how much kinetic energy you can produce in the flywheel motion. You can think of the flywheel as a weight that weighs more if you put more effort into lifting it. Resistance is variable so if you pull less, the flywheel will resist less.

Every repetition in a set can be maximal instead of only the last one, which is the case with traditional weights. This results in a higher training efficiency, earlier onset of strength increase and also hypertrophy\*.

**The potentially higher exertion on the kPulley may lead to a need for longer resting periods between sessions to fully recover.**

\*) Hypertrophy refers to an increase in muscle size achieved through exercise.

## Eccentric Loading

**The kPulley provides for increased eccentric workloads.**

The skeletal muscles can produce more force in the eccentric, or negative phase. This is difficult to take advantage of with traditional weights, which always weigh the same.

If you accelerate the flywheel during the concentric, or lifting phase and then decelerate in a shorter amount of time, you will have to produce a higher eccentric force. This will be similar to lifting weights that would normally be too heavy to lift unless assisted by a training partner, but executing the eccentric (lengthening) phase by yourself. Check out the Excentric Online Academy for more information on eccentric overload.



<https://academy.excentric.com>

# USAGE

Please visit the Exxentric Online Academy for the free getting started course, including demos, video tutorials, the kMeter intro course, and more.

<https://academy.exxentric.com>



## Range of Motion

Stand in front of the kPulley on the floor. The correct range of motion will depend on which exercise you wish to perform.

The range of motion can be set by:

- A. Adjusting the height of the sliding belt stop.
- B. Adjusting the amount of excess belt coming out of the belt stop.
- C. Moving closer or further away from the kPulley.



(0.6m)

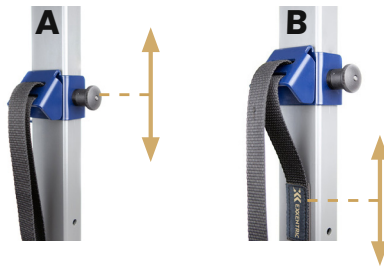

## Setting the Height

You can set the height the belt should come out from the kPulley using the numbers on the beam as a guide.

Pull the knob to release the lock. Hold the sliding part in place and adjust the height, let go of the knob and let it click-in to lock the position.

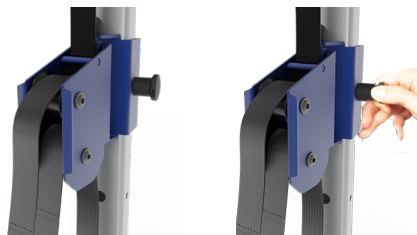
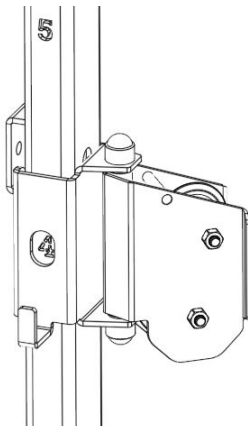

## Exercising

Pull gently for 1-2 repetitions to assess that you have the correct inertia and positioning and then increase to the desired exercise intensity.

For beginners and rehab patients doing lower body exercises, **the top position should be just before all active joints are fully extended.** For experienced users, there can be some slack in the top.

## kPulley Attachment Kit

To attach the kPulley to a pole or a rack, use the brackets on the back of the beam and our kPulley attachment kit.

Make sure to use at least four straps; one at the top and one at the bottom of **each** beam.

**Attention! Do not leave or permanently mount kPulley outside.**



Examples:





# KPULLEY MAINTENANCE

## Drive Belt Cautions

The drive belt and its attachment to the shaft is the most sensitive part of the kPulley. **Be attentive to wear and check regularly.**

When the belt shows signs of wear and tear, trim the end by cutting off the damaged area or replace it with an original spare drive belt.



For recommendations on how to prolong the lifespan of your drive belt, please refer to our videos on best practices, found here:

[www.exxentric.com/support/maintenance/](http://www.exxentric.com/support/maintenance/)

## Trimming a Worn Drive Belt

When the drive belt shows signs of wear and tear, trim the end by cutting off the damaged area or replace it with an original spare drive belt.



If damage occurs close to the shaft it is possible to cut off the damaged end and reattach the new end. You can watch the procedure by scanning the QR code or by following the steps below:

1. Remove the shaft cover, use T30 torx key from the tool kit.

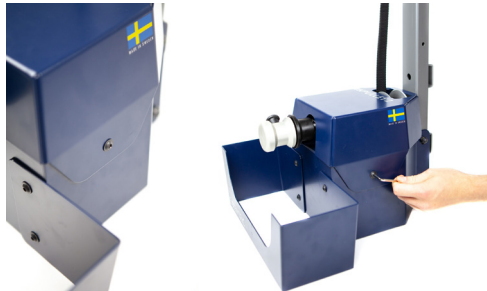

2. Hang the shaft cover on the height adjustment pulley hook.



- Unwind all of the belt from the shaft and use the 3 mm hex key to push the belt through the shaft and remove the lock pin.



- Cut off the damaged belt. Harden the edge with a lighter.



- Pull the belt through the shaft from the side with the narrower groove. Fold the belt around lock pin and pull the belt and pin into the wider groove in the shaft.



- The belt automatically locks into the groove when you pull it firmly. Make sure you can see the edge of the band when it's in place in the shaft (highlighted in third photo above).
- Put the shaft cover back on and start training.

**Note:** If the lock pin is dropped inside the chassis, there is a spare one in the tool kit. If both are lost, remove the chassis from the beam and pick them up.

## Replace the Drive Belt Completely

Remove the belt from the shaft as above, pull it out through the shaft and through the pulley block and the sliding pulley. Untie the drive belt from the belt stop.

Re-attach the new drive belt in the belt stop and reverse the procedure.

# FLYWHEEL WORKOUT ZONES

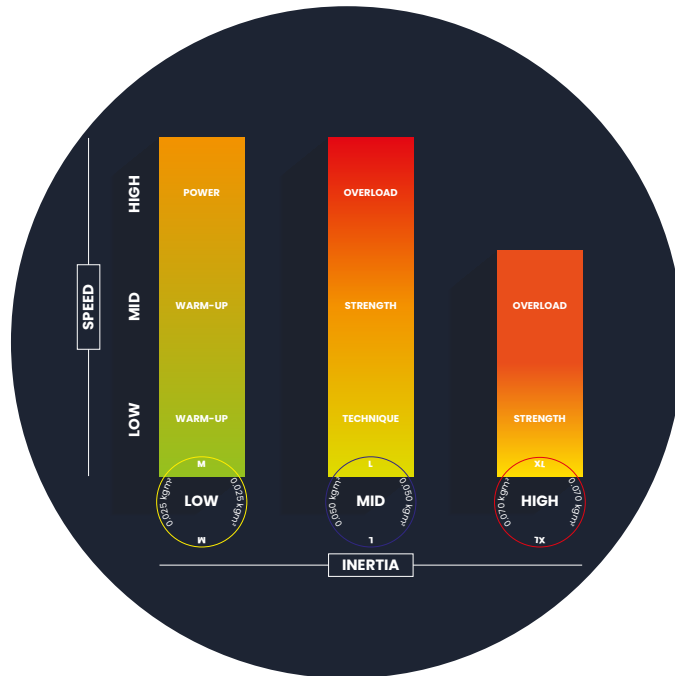

## Warm-up

Low intensity and low to medium inertia

## Power

Max intensity at low inertia

## Technique

Medium inertia and low intensity

## Strength

Medium to high intensity at medium to high inertia

## Higher Inertia

More eccentric overload

For all Exentric devices, we want to stress that new exercises and users should be taught using **MEDIUM** inertia and **LOW INTENSITY**.

Since this will be slow, controlled and submaximal forces, it is easier to correct and there is less risk of injury or technical error. When the technique is correct, increase the intensity and/or lower the inertia for higher speed and more power.



For more information and advice visit the Exentric Online Academy.

<https://academy.exentric.com>

# KMETER

## Overview

The kMeter Module allows you to connect your smartphone or tablet with your kPulley and get live training feedback.

The kPulley has the kMeter II built-in as standard. It is powered by two 1.5 volt AA batteries and located under the base unit cover plate.

## How it Works

The kMeter Module sends wireless data over Bluetooth to the corresponding iOS or Android app.

The kMeter App uses rotational data and user-input of inertia to calculate and present the power in real-time and set a summary containing a wide range of metrics. Users can also input training data after a completed set. All data can be stored in an online database for later viewing in the app or to be exported to Excel.

The kMeter II has a sample rate of 10.000 Hz and receives 64 impulses per revolution of the flywheel. This means it can accurately sample data up to rotational speeds of 155 revolutions/second.



## Download the App

“Exentric kMeter” in App Store and Google Play.



The kMeter II (art. no. 20002) is CE-marked according to 2014/53/EU Radio Equipment Directive, and FCC and ISED-certified.

## About the kMeter



For information about the metrics and their precision, and how to connect the kMeter module with the app, check out the kMeter II Quick Start Guide or the Exentric Online Academy.

<https://academy.exentric.com>

# KPULLEY ACCESSORIES



**Flywheels**  
0.005, 0.010, 0.025, 0.050  
and 0.070 kgm<sup>2</sup>



**kGrips & kBar**  
Ultra light bar



**Hip Belt & Ankle Cuffs**  
Small-Medium, Medium-  
Large



**Harness**  
XXS, XS, S, M, L, XL, XXL



**Head Harness**



**Single-Turn Buckle**



**Advanced Flywheel  
Knob**



**Rotational Sling**



**Advanced Accessory  
Rack**



**Wall Mounted Rack**



**Flywheel Bag**

## Accessories for other devices:

Extension strap for overhead movements, Foot block short (for kBox4 Lite / Active), Foot block long (for kBox4 Pro), Elevation blocks.

*Visit [exentric.com](http://exentric.com) for more info on products and accessories!*

# SUPPORT

## More Information

For downloading the latest manuals, instructions and tutorials:

[www.exentric.com/support](http://www.exentric.com/support)

For maintenance procedures or to continue reading this manual:

[www.exentric.com/maintenance](http://www.exentric.com/maintenance)

Blog posts covering flywheel science and physiology:

[www.exentric.com/news](http://www.exentric.com/news)

**For demos, getting started tutorials, the kMeter intro course, and more, check out:**

<https://academy.exentric.com>

(Register with your email to use this free service)

## Assistance

Send an email to: [support@exentric.com](mailto:support@exentric.com) or [appsupport@exentric.com](mailto:appsupport@exentric.com) (for problems concerning our software or apps)

Emails should include:

1. Serial number, found on the rear of the chassis base.
2. Description of the encountered issue.
3. Preferably attach an image/video for illustration purposes.

# APPS



## Exxentric kMeter

For iOS and Android. Shows real-time data from the kMeter module.

For more information, see the previous kMeter section.



## Flywheel Training

For iOS and Android. Inspirational guide for new users.

Get access to tutorials, create a program and get started!

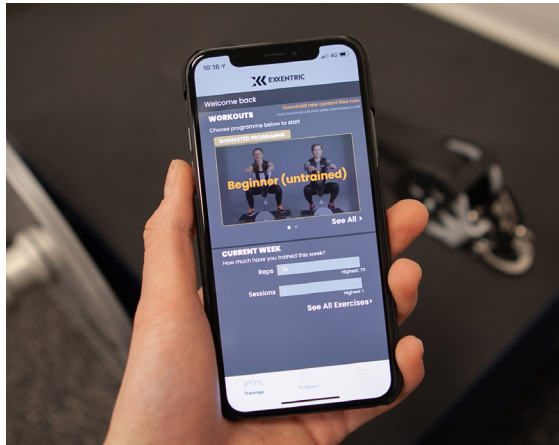

# WARRANTY

Valid from 03-10-2013

- 1) THE TERMS AND CONDITIONS' APPLICABILITY. This Agreement applies only to the sale of products in new condition in the EU or in a market where a certified dealer is established. For the individual consumer, warranty runs from the original delivery date for 12 months in parallel with a three-year legal guarantee. For trade companies, warranty runs for 12 months from the original delivery date and with the conditions set out in this agreement.
- 2) PARTIES OBLIGATIONS. Exxentric undertake - with the exception of the cases specified in paragraph 5 below - in case of malfunction or damage to the product to replace defective parts. More extensive repairs are to be carried out by an Exxentric designated service center.
- 3) WHAT CONSTITUTES AN ERROR. Errors are professionally determined deviations from the normal standard that manifests itself during the period specified in paragraph 1. The product is considered defective if it differs in the manner stated above and is not, according to Exxentric, likely to have been defected due to accident or circumstances that are otherwise attributable to the buyer.
- 4) TROUBLESHOOTING. Rectification of defects or delivery of replacement parts will take place within a reasonable time after the buyer notified the error and, if so requested by Exxentric, made the product available to the action of a designated service centre. What is considered a reasonable time is determined by the buyer's need for the product, the nature and scope of the error, difficulties in determining the error and access to spare parts and engineering capacity.
- 5) LIMITATION OF SELLER / EXXENTRIC'S COMMITMENT. Exxentric's responsibility does not cover the product's consumable parts and wear parts such as for example drive belts, extension straps, rubber protectors for the pulley block, snap hooks, rubber mats and pads. Also, the warranty does not cover what is considered as normal wear and tear, normal corrosion, or defects in paint or other coatings. Also, the buyer may not claim rectification for deficiencies which the seller can show were caused by for example:
  - that repair or service was done elsewhere than at an authorized Exxentric service center
  - that non OEM components were used
  - that use of the product continued after the defect was first noticed
  - that the product has been used in ways for which it is not designed or sized
  - that the product has been abused
  - that the product has not been used with normal care
  - that the care regulations as per existing instructions have not been carefully observed.
- 6) TRANSPORT SAFETY AND TRANSPORTATION EXPENSE. For repair of extensive defects, the purchaser shall bring the product to a designated service center. Buyer shall, after the defect has been remedied, pick up the product from the seller or the designated service center. The product can also be dispatched by the buyer to the seller or to the designated service center. Such transportation shall be at the buyer's sole risk and expense. Replacement parts which the buyer can be expected to replace on his/her own are delivered free of charge to the buyer.
- 7) LIMITATIONS OF LIABILITY. For the individual consumer, the limitation of liability as stated in the current applicable Consumer sales rules applies. The buyer is therefore not entitled to compensation beyond what is covered under (2). For commercial customers, Exxentric's liability is limited to what is stated in this agreement. The buyer, therefore, is not entitled to compensation for economic damages beyond the terms specified above, ie not for personal injury or property damage. Buyer is reminded once again the importance of the product being handled with care and in accordance with the operating manual's instructions!

DISPUTES. Disputes concerning the interpretation or application of this Warranty Agreement shall in the first instance be resolved by agreement between the parties. If such an agreement can not be reached, the dispute shall be settled finally by arbitration at the Stockholm Chamber of Commerce Arbitration Institute (the Institute). The Rules for Expedited Arbitrations shall apply unless the Institute with regard to the case, the amount in dispute and other circumstances, determines the rules of the Stockholm Chamber of Commerce Arbitration Institute shall apply to proceedings. In the latter case, the Institute shall also decide whether the arbitral tribunal shall be composed of one or three arbitrators.







# Exxentric Online Academy

Home of Exxentric's online course offering:

- Free Webinars and Tutorials
- Complete Online Certification Courses (Level I and Level II)
- And much more

Start here





[/go\\_exxentric](#)



[/go\\_exxentric](#)



[/go.exxentric](#)

